

# Fortune Series 281

**1/2" & 3/4" , Forged Brass, Full Port,  
Two-Piece Construction,  
200 WOG Valves Conform To MSS SP-110.  
Inlet: MIP Threaded Or Solder  
Outlet: HOSE Threaded**

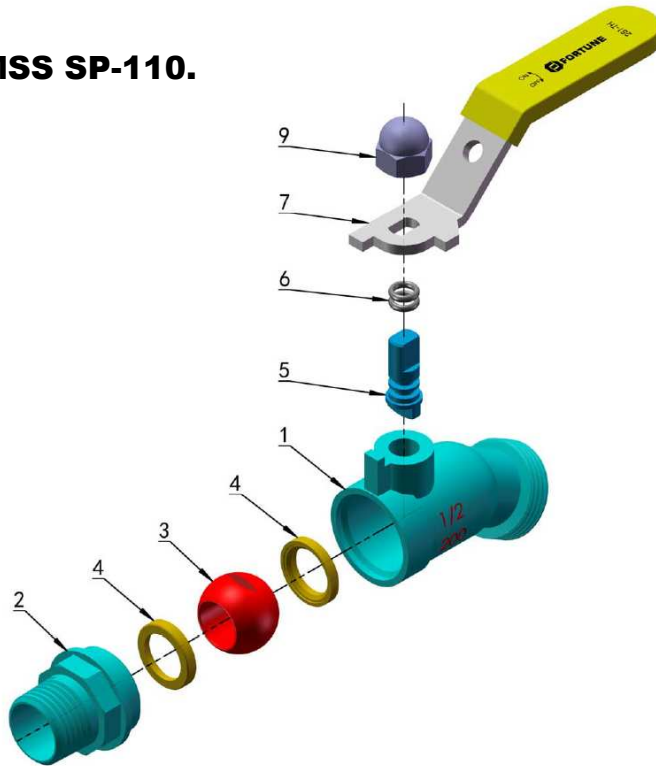

### Bill of Materials

ITEM	PART	SPECIFICATION		Q'TY
1	BODY	FORGED BRASS	LEAD-FREE BRASS	1
2	END CAP	FORGED BRASS	LEAD-FREE BRASS	1
3	BALL	COPPER ALLOY, CHROME PLATED	LEAD-FREE BRASS, CHROME PLATED	1
4	SEAT	PTFE	PTFE	2
5	STEM	COPPER ALLOY	COPPER ALLOY	1
6	O-RING	NBR	NBR	2
7	HANDLE	CARBON STEEL PLATED	CARBON STEEL PLATED	1
8	NUT	CARBON STEEL PLATED	CARBON STEEL PLATED	1

### 281-TH/LF281-TH

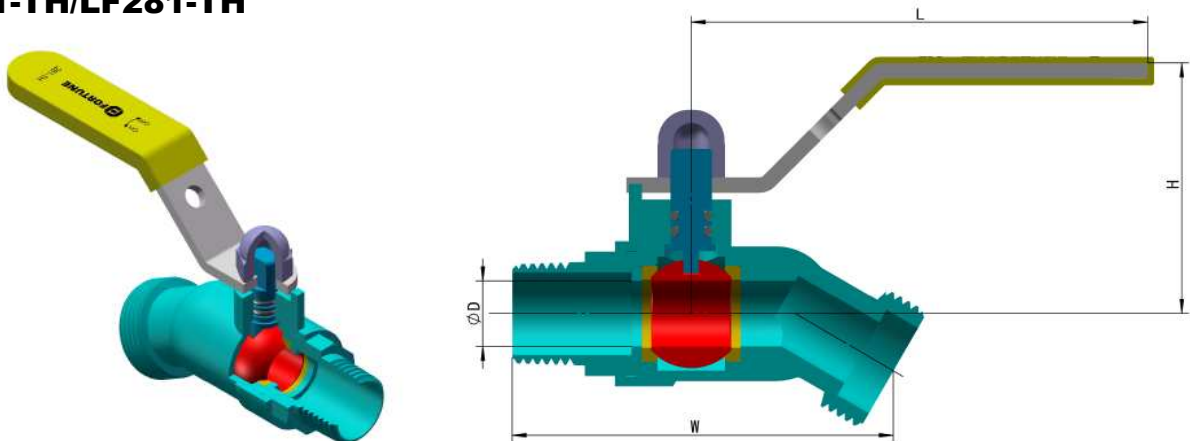

### Weights and Dimensions

SIZE	D	W	H	L	Weight
In / DN	In / mm	In / mm	In / mm	In / mm	Lb / Kg
1/2 / 15	0.50 / 12.7	2.89 / 73.5	1.90 / 48.3	3.46 / 88	0.51 / 0.23
3/4 / 20	0.75 / 19.0	3.29 / 83.6	2.02 / 51.3	3.46 / 88	0.73 / 0.33

# Fortune Series 284

**1/2" & 3/4" , Forged Brass, Full Port, Two-Piece Construction, 200 WOG  
Valves Conform To MSS SP-110.**

**Inlet: FIP Threaded & Solder**

**Outlet: HOSE Threaded**

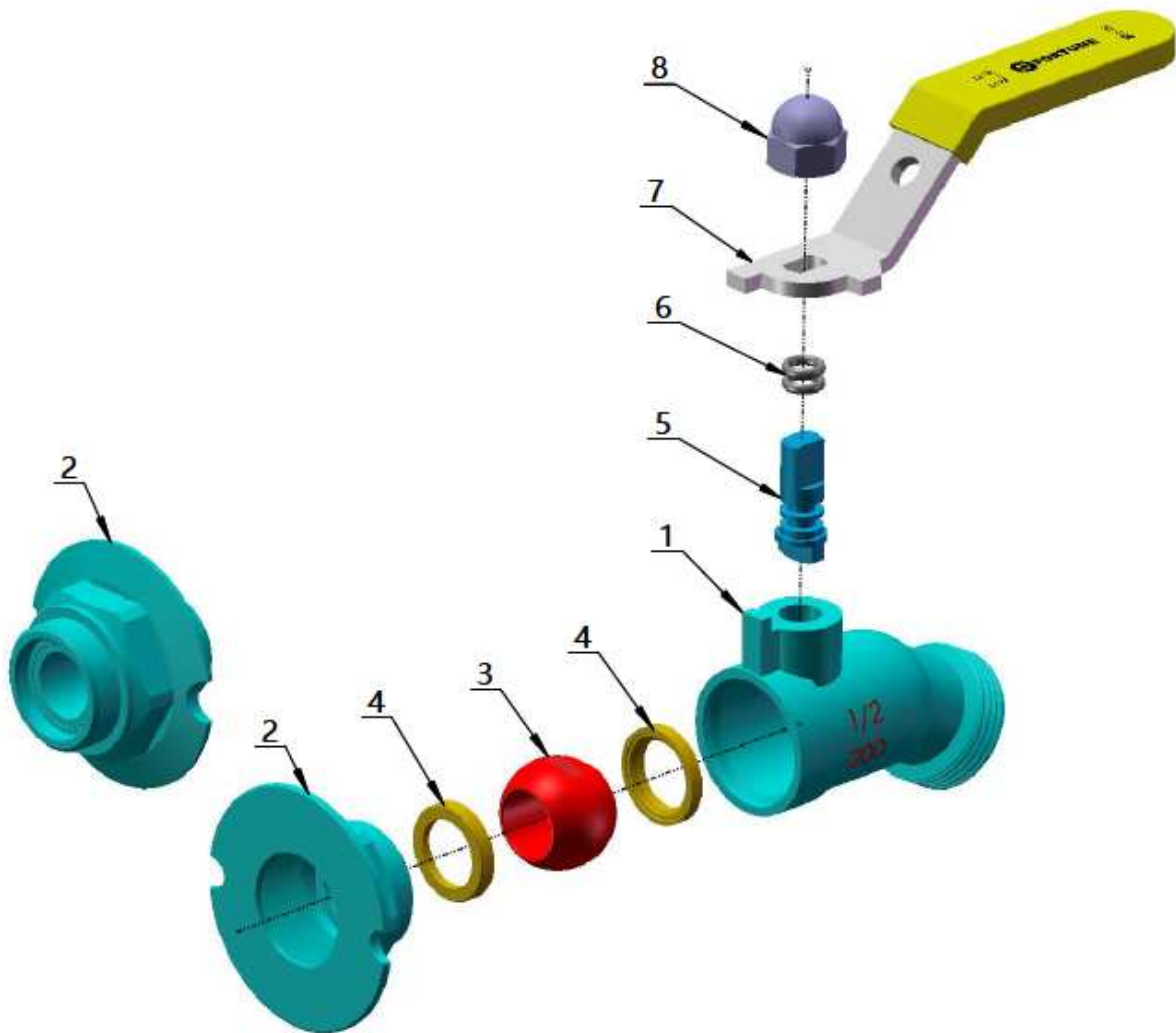

## Bill of Materials

ITEM	PART	SPECIFICATION		Q'TY
1	BODY	FORGED BRASS	LEAD-FREE BRASS	1
2	END CAP	FORGED BRASS	LEAD-FREE BRASS	1
3	BALL	COPPER ALLOY, CHROME PLATED	LEAD-FREE BRASS, CHROME PLATED	1
4	SEAT	PTFE	PTFE	2
5	STEM	COPPER ALLOY	COPPER ALLOY	1
6	O-RING	NBR	NBR	2
7	HANDLE	CARBON STEEL PLATED	CARBON STEEL PLATED	1
8	NUT	CARBON STEEL PLATED	CARBON STEEL PLATED	1

# Fortune Series 284

## 284-TH/LF284-TH

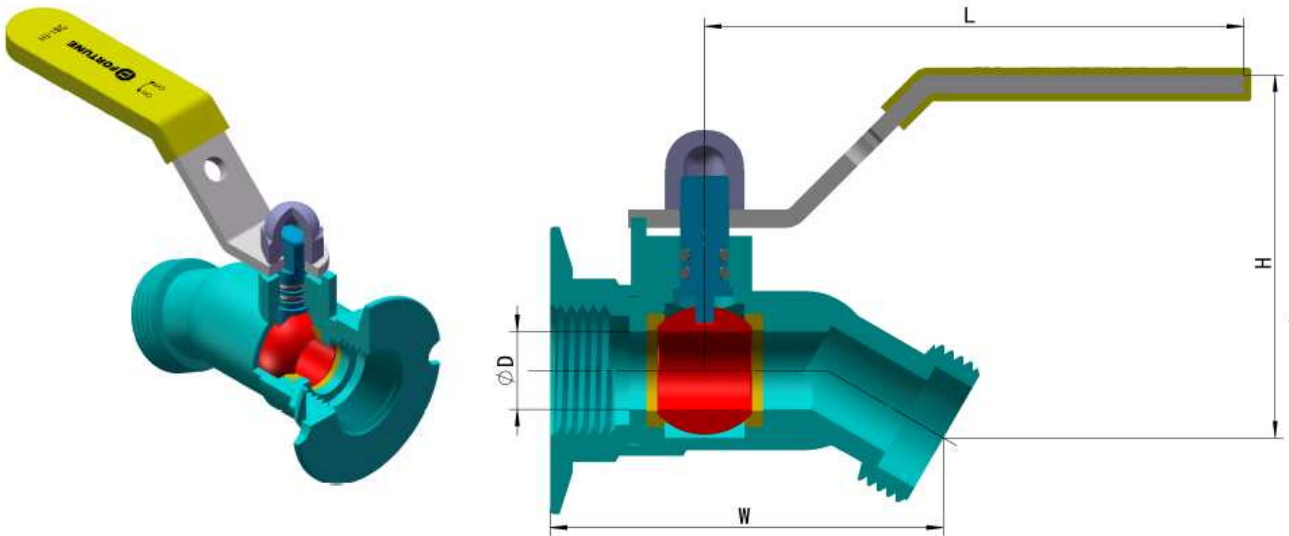

### Weights and Dimensions

SIZE	D	W	H	L	Weight
In / DN	In / mm	In / mm	In / mm	In / mm	Lb / Kg
1/2 / 15	0.50 / 12.7	2.51 / 63.7	1.90 / 48.3	3.46 / 88	0.57 / 0.26
3/4 / 20	0.75 / 19.0	2.81 / 71.5	2.02 / 51.3	3.46 / 88	0.79 / 0.36

## 284-CH/LF284-CH

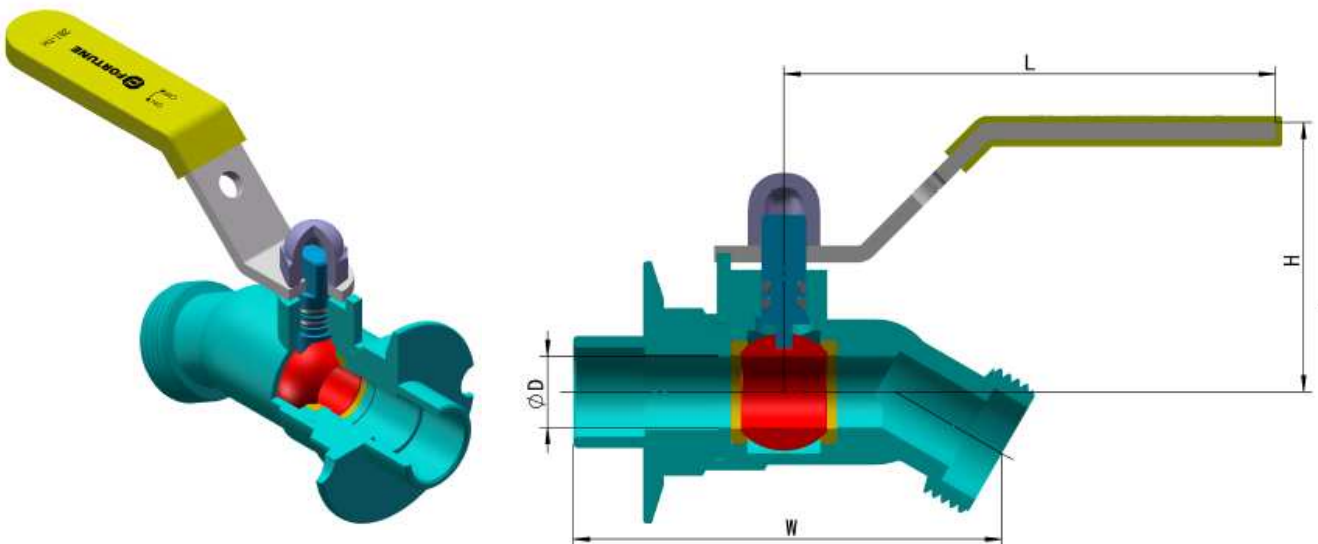

### Weights and Dimensions

SIZE	D	W	H	L	Weight
In / DN	In / mm	In / mm	In / mm	In / mm	Lb / Kg
1/2 / 15	0.50 / 12.7	3.00 / 76.2	1.90 / 48.3	3.46 / 88	0.66 / 0.30
3/4 / 20	0.75 / 19.0	3.31 / 84.0	2.02 / 51.3	3.46 / 88	0.88 / 0.40

# Fortune Series 285

**1/2" & 3/4", Forged Brass, Regular Port,  
Two-Piece Construction,  
200 WOG Valves Conform To MSS SP-110.  
Inlet: MIP Threaded or Solder  
Outlet: HOSE Threaded**

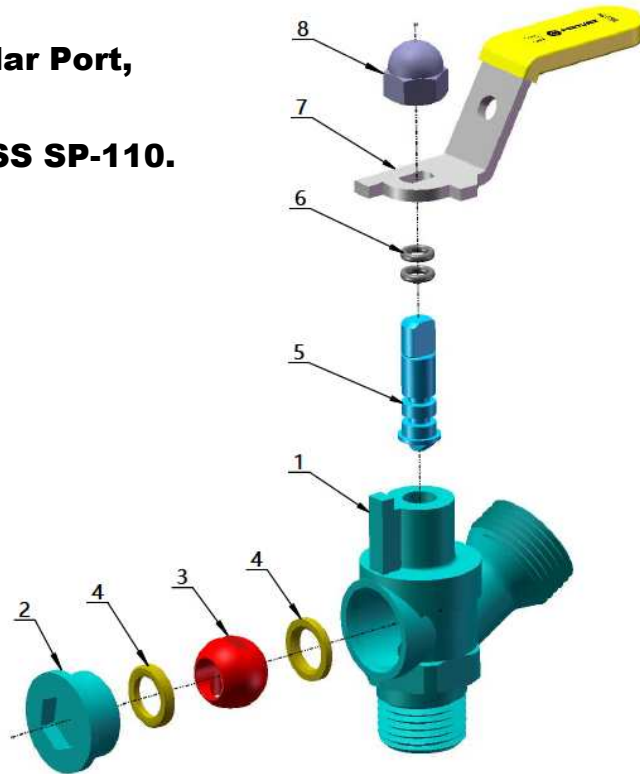

## Bill of Materials

ITEM	PART	SPECIFICATION		Q'TY
1	BODY	FORGED BRASS	LEAD-FREE BRASS	1
2	END CAP	FORGED BRASS	LEAD-FREE BRASS	1
3	BALL	COPPER ALLOY, CHROME PLATED	LEAD-FREE BRASS, CHROME PLATED	1
4	SEAT	PTFE	PTFE	2
5	STEM	COPPER ALLOY	COPPER ALLOY	1
6	O-RING	NBR	NBR	2
7	HANDLE	CARBON STEEL PLATED	CARBON STEEL PLATED	1
8	NUT	CARBON STEEL PLATED	CARBON STEEL PLATED	1

## 285-TH/LF285-TH

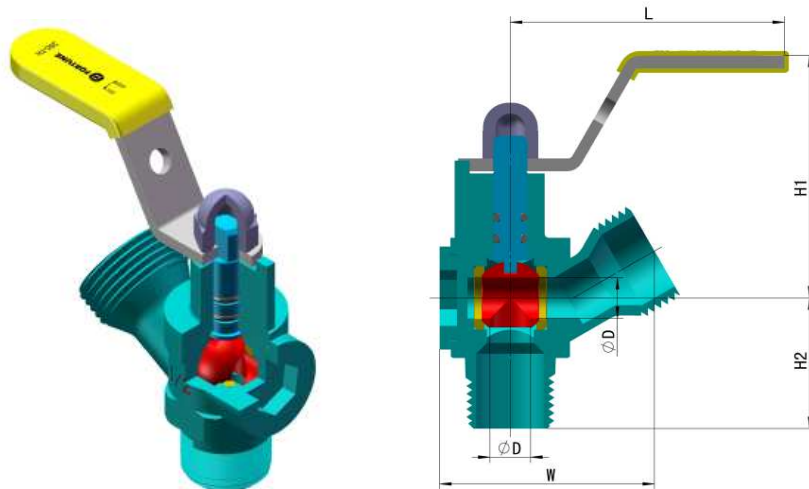

## Weights and Dimensions

SIZE	D	W	H1	H2	L	Weight
In / DN	In / mm	In / mm	In / mm	In / mm	In / mm	Lb / Kg
1/2 / 15	0.43 / 11	19.7 / 50.1	1.90 / 48.3	1.20 / 30.5	2.52 / 64	0.51 / 0.23
3/4 / 20	0.43 / 11	1.97 / 50.1	2.02 / 51.3	1.20 / 30.5	2.52 / 64	0.53 / 0.24

# Fortune Series 286

**1/2" & 3/4", Forged Brass, Full Port,  
Two-Piece Construction,  
200 WOG Valves Conform To MSS SP-110.  
Inlet: FIP Threaded  
Outlet: HOSE Threaded**

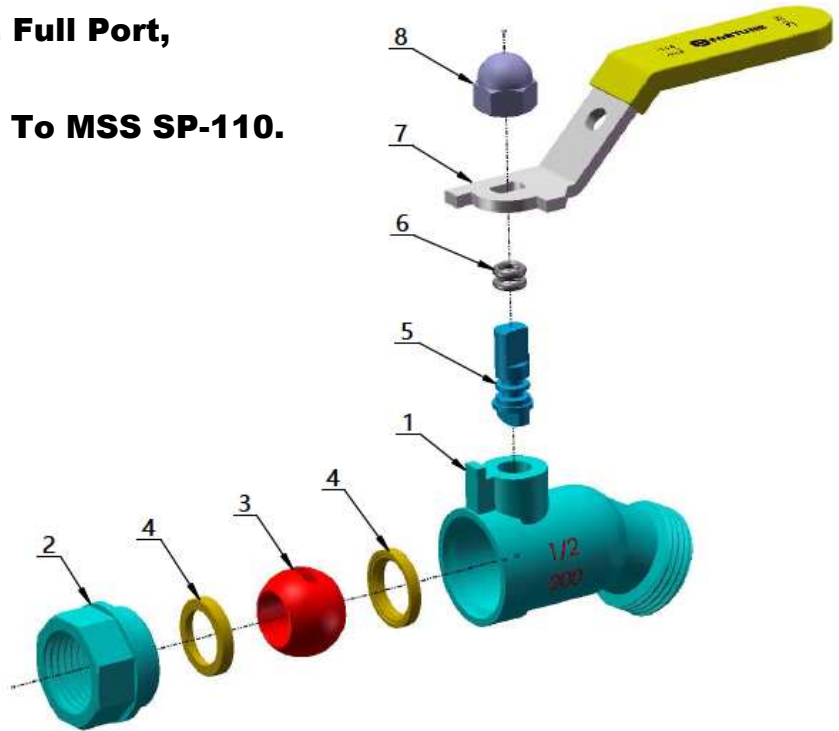

### Bill of Materials

ITEM	PART	SPECIFICATION		Q'TY
1	BODY	FORGED BRASS	LEAD-FREE BRASS	1
2	END CAP	FORGED BRASS	LEAD-FREE BRASS	1
3	BALL	COPPER ALLOY, CHROME PLATED	LEAD-FREE BRASS, CHROME PLATED	1
4	SEAT	PTFE	PTFE	2
5	STEM	COPPER ALLOY	COPPER ALLOY	1
6	O-RING	NBR	NBR	2
7	HANDLE	CARBON STEEL PLATED	CARBON STEEL PLATED	1
8	NUT	CARBON STEEL PLATED	CARBON STEEL PLATED	1

### 286-TH/LF286-TH

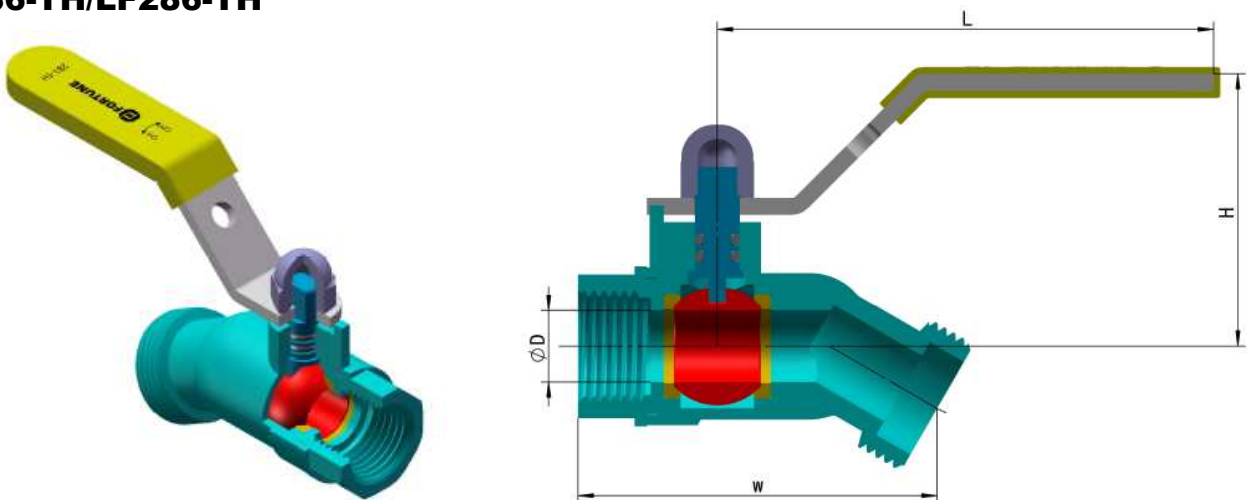

### Weights and Dimensions

SIZE	D	W	H	L	Weight
In / DN	In / mm	In / mm	In / mm	In / mm	Lb / Kg
1/2 / 15	0.50 / 12.7	2.51 / 63.7	1.90 / 48.3	3.46 / 88	0.49 / 0.22
3/4 / 20	0.75 / 19.0	2.81 / 71.5	2.02 / 51.3	3.46 / 88	0.66 / 0.30